

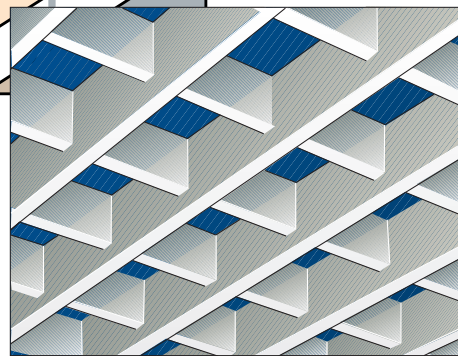

ShanghaiProfil

Gridal 12

METAL OPEN CELL
CEILING RANGE

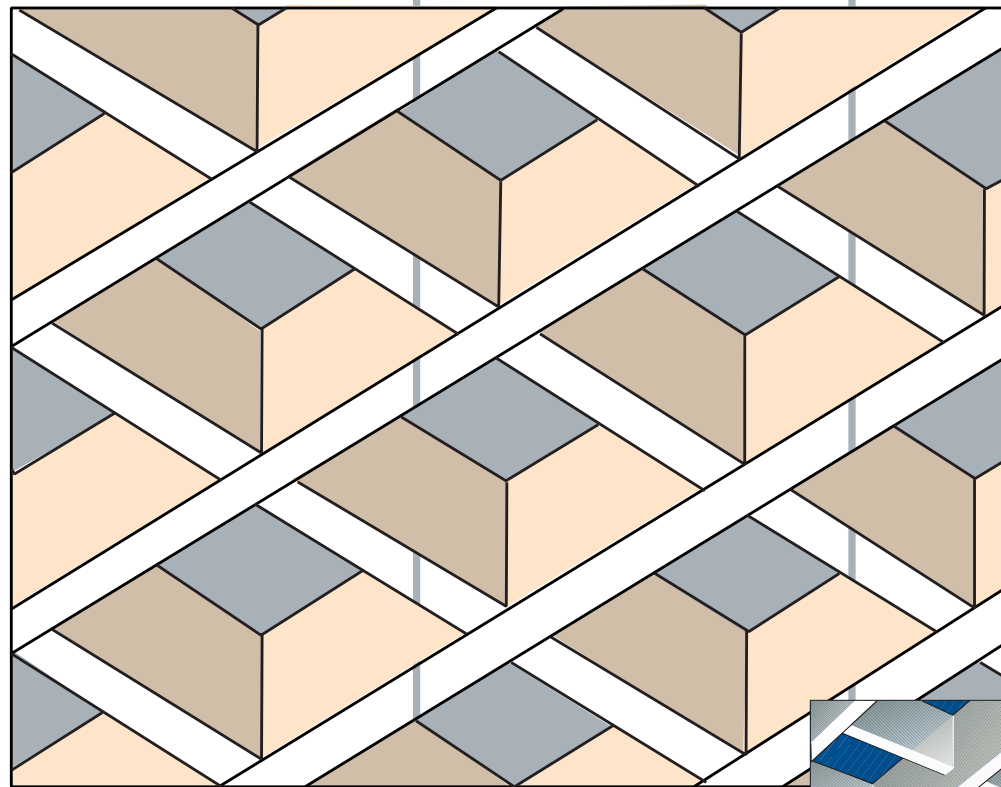

BI-PLANAR CELLS

ShanghaiProfil Metal Ceiling Co., Ltd.
No. 30, Lane 1125, Nanliu Road,
Pudong New Area, 201300 Shanghai
P.R. China

Tel: (+86)-21-5803 3985
E-mail: info@shanghaiprofil.com
Fax: (+86)-21-5803 3990
Internet: www.shanghaiprofil.com

1

Intersected 12mm wide cell blades made from folded aluminium in the thicknesses shown in Table 2.

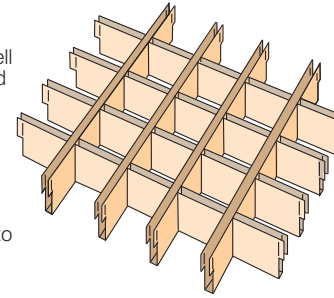

Standard finish: colour white similar RAL 9010.
Special finishes: subject to minimum order quantity.

Table 2 Cell dimensions and aluminium thicknesses.

Legend A Cell dimension as Fig.3 in mm.
B Cell dimension as Fig.3 in mm.
H Cell height as Fig.3 in mm.

A	B	H = 40	H = 57	H = 75
50	50	0.4	0.5	0.6
60	60	0.4	0.5	0.6
75	75	0.4	0.5	0.6
86	86	0.4	0.5	0.6
100	100	0.4	0.5	0.6
120	120	0.4	0.5	0.6
150	150	0.4	0.5	0.6
200	200	0.4	0.5	0.6
300	300	0.4	0.5	0.6
600	600	0.4	0.5	0.6

Note Refer to inside pages for Fig.3 dimensions

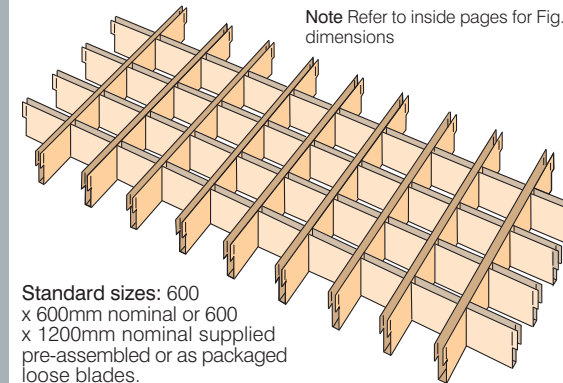

Standard sizes: 600 x 600mm nominal or 600 x 1200mm nominal supplied pre-assembled or as packaged loose blades.

Standard cell sizes: shown in Table 2.

2i

Gridal 12 main runners in folded aluminium of the thicknesses shown in Table 2. Cutout spacings to suit cell sizes.
Standard finish: as 1
Standard lengths: 3000mm
Overall size: 12mm wide x height as Table 2.

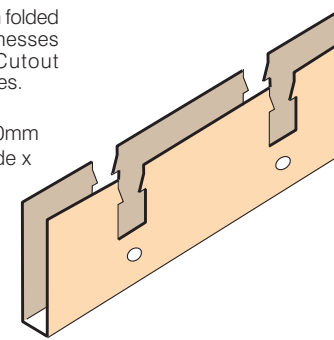

2ii

Gridal 12 lateral runners in folded aluminium of the thicknesses shown in Table 2. Cutout spacings to suit cell sizes.
Standard finish: as 1
Standard lengths: 1200mm nominal.
Overall size: 12mm wide x height as Table 2.

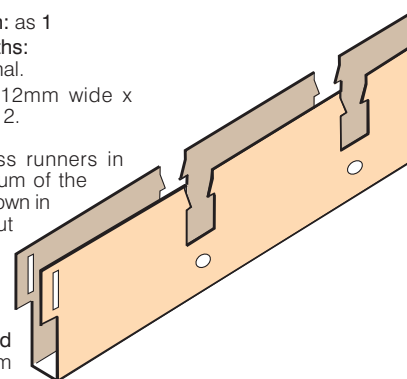

2iii

Gridal 12 cross runners in folded aluminium of the thicknesses shown in Table 2. Cutout spacings to suit cell sizes.
Standard finish: as 1
Standard lengths: 600mm nominal.
Overall size: 12mm wide x height as Table 2.

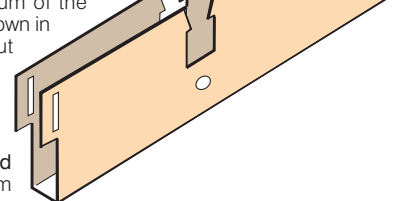

2A

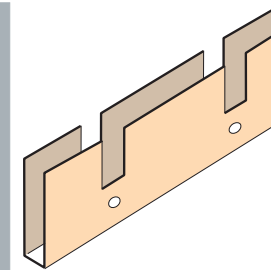

'U' coupler for Gridal 12 main runners in 0.4/0.5/0.6mm thick aluminium. Lengths between 150-300mm to suit cell size. Finish as carriers.

3

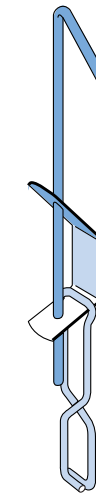

Butterfly suspension key hangers with spring clips and 4mm dia. rod.
Standard lengths: various between 125mm min. and 1000mm max. ceiling void depths.

4

Reference number allocation to a component is based on its function in the ceiling system. No Gridal 12 component suits 4 classification.

5i

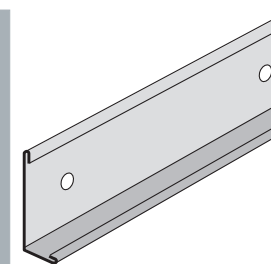

Perimeter angle trim in cold roll formed 0.6mm thick aluminium.
Standard finish: stove enamel polyester paint to match Gridal 12 panels applied to all surfaces.
Standard length: 4000mm
Overall size: 40mm deep x 20mm wide.

5ii

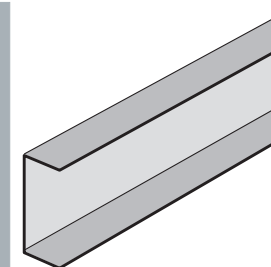

Floating edge perimeter capping channel in press braked 0.4/0.5mm thick aluminium.
Standard finish: stove enamel polyester paint to match Gridal 12 panels applied to all surfaces.
Standard length: 2400mm
Overall size: depth to suit height of Gridal 12 panels with 2 no's legs 12mm wide.

6

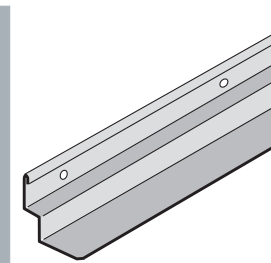

Perimeter shadow line angle trim in cold roll formed 0.6mm thick aluminium.
Standard finish: stove enamel polyester paint to match Gridal 12 panels applied to all surfaces.
Standard length: 4000mm
Overall size: 44mm deep x 36.5mm wide.
Shadow gap width 12.5mm.

